



TENTEC

OPERATOR'S
MANUAL

HERCULES II

MODEL 420
LINEAR AMPLIFIER

TABLE OF CONTENTS

<u>PARAGRAPH</u>	<u>PAGE</u>
LIST OF ILLUSTRATIONS	iii
SPECIFICATIONS	iv
INTRODUCTION	v
UNPACKING	v
1. INSTALLATION	
1-1 INTRODUCTION	1-1
1-2 POWER SUPPLY TO RF AMPLIFIER INTERCONNECTIONS	1-1
1-3 EXCITER INTERCONNECTIONS	1-1
1-4 ANTENNA REQUIREMENTS	1-2
1-5 GROUND CONNECTIONS	1-2
2. OPERATING INSTRUCTIONS	
2-1 INTRODUCTION	2-1
2-2 FRONT PANEL CONTROL FUNCTIONS	2-1
2-2.1 BAND	2-1
2-2.2 POWER	2-1
2-2.3 CONTROL MODE	2-1
2-2.4 METER	2-1
2-2.5 PEAK POWER METER	2-1
2-2.6 OVERDRIVE	2-1
2-3 REAR PANEL CONNECTOR FUNCTIONS	2-2
2-3.1 RF INPUT	2-2
2-3.2 RF OUTPUT	2-2
2-3.3 DC POWER	2-2
2-3.4 KEY IN	2-2
2-3.5 KEY OUT	2-2
2-3.6 VOX KEY IN	2-2
2-3.7 SPEAKER	2-2
2-3.8 REMOTE CONTROL	2-2
2-4 INITIAL TURN-ON	2-2
2-5 TUNE UP PROCEDURE (CW/RTTY/SSTV/FM)	2-2
2-6 TUNE UP PROCEDURE (SSB)	2-3
2-7 FAULT CONDITIONS	2-3

TABLE OF CONTENTS (continued)

<u>PARAGRAPH</u>	<u>PAGE</u>
.....	3-1
SWITCHING	3-1
E CONTROL	3-1
I THE 22-30 MHZ BAND	3-1
 CIRCUIT SCHEMATICS	
.....	4-1
BOARD (81430)	4-5
BOARD (81427)	4-9
BOARD (81428)	4-15
BOARD (81429)	4-19
(81444)	4-25
BOARD (81406)	4-29
BOARD (81405)	4-35
1426)	4-39
D (81424)	4-43
BOARD (81423)	4-47
PLAY BOARD (81431)	4-51
 3. OPERATING HINTS	
3-1 INTRODUCTION	3-1
3-1.1 REMOTE BAND	3-1.1
3-1.2 TOTAL REMOTE	3-1.2
3-1.3 OPERATION ON	3-1.3
 4. ILLUSTRATIONS AND CIRCUITS	
4-1 INTRODUCTION	4-1
4-2 INPUT SPLITTER BOARD	4-2
4-3 RF POWER AMP. BOARD	4-3
4-4 POWER AMP. DUMP BOARD	4-4
4-5 LOW PASS FILTER BOARD	4-5
4-6 VAC RELAY BOARD	4-6
4-7 D.C. DISTRIBUTION BOARD	4-7
4-8 POWER AMP. BIAS BOARD	4-8
4-9 CONTROL BOARD (81423)	4-9
4-10 BANDSWITCH BOARD	4-10
4-11 BANDSWITCH LED BOARD	4-11
4-12 LED BARGRAPH DISPLAY BOARD	4-12

LIST OF ILLUSTRATIONS

<u>FIGURE</u>	<u>PAGE</u>
1-1 CONNECTION DIAGRAM FOR 12-14 VDC POWER	1-3
1-2 TEN-TEC TRANSCEIVERS (WITH TX OUT & TX EN)	1-3
1-3 HOOKUP DIAGRAM FOR VOX RELAY CONTROL	1-4
1-4 HOOKUP FOR OTHER TRANSCEIVERS WITH SLOW KEYING	1-4
2-1 MODEL 420 FRONT PANEL	2-5
2-2 MODEL 420 REAR PANEL	2-5
2-3 MODEL 420 TOP VIEW	2-6
2-4 MODEL 420 BOTTOM VIEW	2-6
3-1 REMOTE BANDSWITCH ADAPTER CABLE — OMNI / CORSAIR I	3-3
3-2 HERCULES II REMOTE CONTROL CONNECTOR PINOUT	3-3
4-1 MODEL 420 AMPLIFIER WIRING DIAGRAM	4-3
4-2 81430 INPUT SPLITTER BOARD CIRCUIT TRACE	4-5
4-3 81430 INPUT SPLITTER BOARD COMPONENT LAYOUT	4-5
4-4 81430 INPUT SPLITTER BOARD SCHEMATIC	4-7
4-5 81427 RF POWER AMP. BOARD CIRCUIT TRACE, BOTTOM	4-9
4-6 81427 RF POWER AMP. BOARD COMPONENT LAYOUT	4-11
4-7 81427 RF POWER AMP. BOARD SCHEMATIC	4-13
4-8 81428 POWER AMP. DUMP BOARD CIRCUIT TRACE	4-15
4-9 81428 POWER AMP. DUMP BOARD COMPONENT LAYOUT	4-15
4-10 81428 POWER AMP. DUMP BOARD SCHEMATIC	4-17
4-11 81429 LOW PASS FILTER BOARD CIRCUIT TRACE	4-19
4-12 81429 LOW PASS FILTER BOARD COMPONENT LAYOUT	4-21
4-13 81429 LOW PASS FILTER BOARD SCHEMATIC	4-23
4-14 81444 VAC RELAY BOARD CIRCUIT TRACE	4-25
4-15 81444 VAC RELAY BOARD COMPONENT LAYOUT	4-25
4-16 81444 VAC RELAY BOARD SCHEMATIC	4-27
4-17 81406 D.C. DISTRIBUTION BOARD CIRCUIT TRACE	4-29
4-18 81406 D.C. DISTRIBUTION BOARD COMPONENT LAYOUT	4-31
4-19 81406 D.C. DISTRIBUTION BOARD SCHEMATIC	4-33
4-20 81405 POWER AMP. BIAS BOARD CIRCUIT TRACE	4-35
4-21 81405 POWER AMP. BIAS BOARD COMPONENT LAYOUT	4-35
4-22 81405 POWER AMP. BIAS BOARD SCHEMATIC	4-37
4-23 81426 CONTROL BOARD CIRCUIT TRACE	4-39
4-24 81426 CONTROL BOARD COMPONENT LAYOUT	4-39
4-25 81426 CONTROL BOARD SCHEMATIC	4-41
4-26 81424 BANDSWITCH BOARD CIRCUIT TRACE	4-43
4-27 81424 BANDSWITCH BOARD COMPONENT LAYOUT	4-43
4-28 81424 BANDSWITCH BOARD SCHEMATIC	4-45
4-29 81423 BANDSWITCH LED BOARD CIRCUIT TRACE	4-47
4-30 81423 BANDSWITCH LED BOARD COMPONENT LAYOUT	4-47
4-31 81423 BANDSWITCH LED BOARD SCHEMATIC	4-49
4-32 81431 LED BARGRAPH DISPLAY BOARD CIRCUIT TRACE	4-51
4-33 81431 LED BARGRAPH DISPLAY BOARD COMPONENT LAYOUT	4-51
4-34 81431 LED BARGRAPH DISPLAY BOARD SCHEMATIC	4-53

SPECIFICATIONS

OPERATING FREQUENCY:	1.8 to 30 MHz in seven bands. (22-30 MHz Band is disabled on domestic model).
MAXIMUM POWER:	550 watts output CW, RTTY and SSB. (1 KW dc input).
DRIVE POWER REQUIRED:	50 to 80 watts typical for 550 watts output.
DUTY CYCLE:	SSB- continuous voice modulation; CW/RTTY- 50% duty cycle continuously; 15 minutes maximum continuous key-down at 550 watts output.
DISTORTION:	Third order products -35dB from 550 watt output level.
INPUT AND OUTPUT IMPEDANCES:	50 ohms unbalanced, VSWR < 2:1.
METERING:	Switch selectable Forward Power, SWR (calibrated @ 500W Forward Power), Icc (collector current), Vcc (collector voltage). Ten element LED bargraph instantly displays Peak Output Power.
TX/RX SWITCHING TIME:	Less than 5 mS.
PROTECTIVE CIRCUITS:	Hot switching T/R protection. Over-voltage and over-current lockout. Automatically switched input pad in overdriven condition. Front panel "overdrive" LED indicates fault condition.
PRIMARY POWER:	RF Deck — 12.5-14 volts @ 80 amps. (100 amps maximum).
FINAL AMPLIFIER TRANSISTORS:	Eight MRF458, SD1405, or equivalent.
COOLING:	Internal forced air, rear exhaust.
FRONT PANEL CONTROLS:	Power (ON-OFF), Control (QSK/RELAY), Meter (FWD, REF, Ic, Vcc), Band (REMOTE, 1.8-2.5, 2.5-4.0, 4.0-6.5, 6.5-10.5, 10.5-15.0, 15.0-22.0, 22.0-30.0).
REAR PANEL CONNECTIONS:	RF Input, RF Output, DC Power, Key In, Key Out, Vox Key, Speaker, Remote Control, Grounds.
SIZE:	17.5" x 19" x 14" (443 x 483 x 356 mm).
WEIGHT:	15 lbs. (6.8 Kg).

INTRODUCTION

The HERCULES II Model 420 is a _____ output SSB PEP or 50% duty cycle CW; 15

CHAPTER 1

INSTALLATION

1-1 INTRODUCTION When setting up the station, provide adequate ventilation for the amplifier and power supply. Also, select a location that allows adequate clearance for rear panel connections.

1-2 POWER SUPPLY TO RF AMPLIFIER INTERCONNECTIONS Connecting the Model 9420 AC Power Supply is straight-forward. Refer to the Model 9420 operator's manual to configure the supply for either 120 or 240 Vac operation. To connect the 9420 Power Supply proceed as follows:

- 1] Be sure the HERCULES II Power switch is turned off and the power supply is unplugged from the wall outlet.
- 2] Push the 12 pin dc power plug from the supply firmly into the mating DC POWER connector on the rear panel of the HERCULES II until the locking tabs snap into place.
- 3] If you wish to power your transceiver from the Model 9420 also, push one end of the double 4 pin connector dc cable supplied with the 9420 firmly into the mating 4 pin connector on the power supply. Turn your transceiver Power switch off. Connect the other end of the cable to your transceiver.
- 4] Plug the power supply line cord into a wall outlet of the correct voltage and current rating. You should now be ready to connect your antenna, trans-

ceiver and other station equipment as described in the next section.

OTHER DC SUPPLIES — For mobile or portable operation, the HERCULES II can be powered from any negative ground dc power source capable of supplying 12.5-14 volts at 80 amperes. Figure 1-1 shows the connections required for dc operation.

1-3 EXCITER INTERCONNECTIONS

The first thing to remember about amplifier-transceiver interconnection is that the amplifier **MUST** be keyed into the transmit mode **BEFORE** rf drive power is delivered to the input connector. The HERCULES II incorporates protective circuitry which senses the presence of rf on the antenna coax and prevents the amplifier T/R relays from switching if rf is present.

There are two keying inputs to the HERCULES II. A "key" command on either of these inputs is sufficient to place the amplifier into the transmit mode. Two of the rear panel connectors are labeled "KEY IN" and "KEY OUT". A connection to ground on the KEY IN connector will place the HERCULES II in transmit (assuming no rf is present when the connection is made). A closure to ground on the KEY IN is fed directly to the KEY OUT connector, which can then be used as a key output. Ten-Tec transceivers with "TX OUT" and "TX EN" connectors (such as the Model 585 PARAGON) can be cabled to the "KEY IN" and "KEY OUT" connectors of the HER-

CULES II as shown in FIGURE 1-2. This is the only keying connection necessary for these transceivers. When using this keying system the HERCULES II Control Mode switch should be placed in the QSK position for all operating modes.

A second keying connector on the rear panel of the HERCULES II is labeled "VOX KEY". This input has the same function as the KEY IN and KEY OUT connectors, but is diode isolated from them and therefore can only be used as an input. Also, the "VOX KEY" input is only connected to the internal keying circuitry of the HERCULES II when

the front panel Control Mode switch is placed in the RELAY position. When this switch is in the RELAY position, a ground at the VOX KEY connector will put the HERCULES II into the transmit mode. No ground signal is fed to the KEY OUT connector from the VOX KEY input. Amplifier keying via the VOX KEY connector permits non-QSK (semi break-in) CW and PTT/VOX SSB operation with transceivers that have fast mechanical or solid state keying relay outputs. The transceiver keying relay MUST provide a closure to ground BEFORE rf output appears or the HERCULES II will refuse to switch to transmit with the exciter, but will wait for the first pause in drive, typically switching in after the first dit on CW or the first syllable on SSB. FIGURE 1-3 shows a hookup that can be used with transceivers having fast keying relay outputs. When using this hookup system, the Control Mode switch should be placed in the RELAY position. This system is to be used with semi break-in CW or SSB vox relay keying only.

If your transceiver has a slow vox relay (one which closes after rf output appears), proper CW and PTT operation can be obtained by using the hookup shown in FIGURE 1-4. Vox operation may still drop the first syllable of speech if the relay is too slow. The HERCULES II Control Mode switch should be

placed in the QSK position for CW and in the RELAY position for SSB. This hookup will also work fine for VOX if the PTT/RELAY line goes low fast enough when the VOX is activated.

1-4 ANTENNA REQUIREMENTS The HERCULES II amplifier has been designed for use with antennas resonant at the frequency of operation and having impedances within the limits of 25 to 100 ohms, and an SWR of 2:1 or less.

The nominal output impedance of the amplifier is 50 ohms and the SWR of the load

should not exceed 2:1. Many antennas exhibit an SWR range over an entire amateur band that exceeds 2:1. For operation under this condition, we recommend using an antenna matching network which will enable the HERCULES II to work into a 50 ohm load for maximum power transfer to the antenna. The TEC Model 229 or 238 Tuner is a suitable companion.

CAUTION!!!

Never attempt to operate the HERCULES II without first connecting a suitable antenna or 50 ohm dummy load of sufficient power rating or **SERIOUS DAMAGE MAY RESULT.**

1-5 GROUND CONNECTIONS In the interest of personal safety and to reduce the possibility of stray RF pickup on interconnecting cables, all station equipment should be well grounded to earth. It is important to strap all equipment chassis together with short heavy leads.

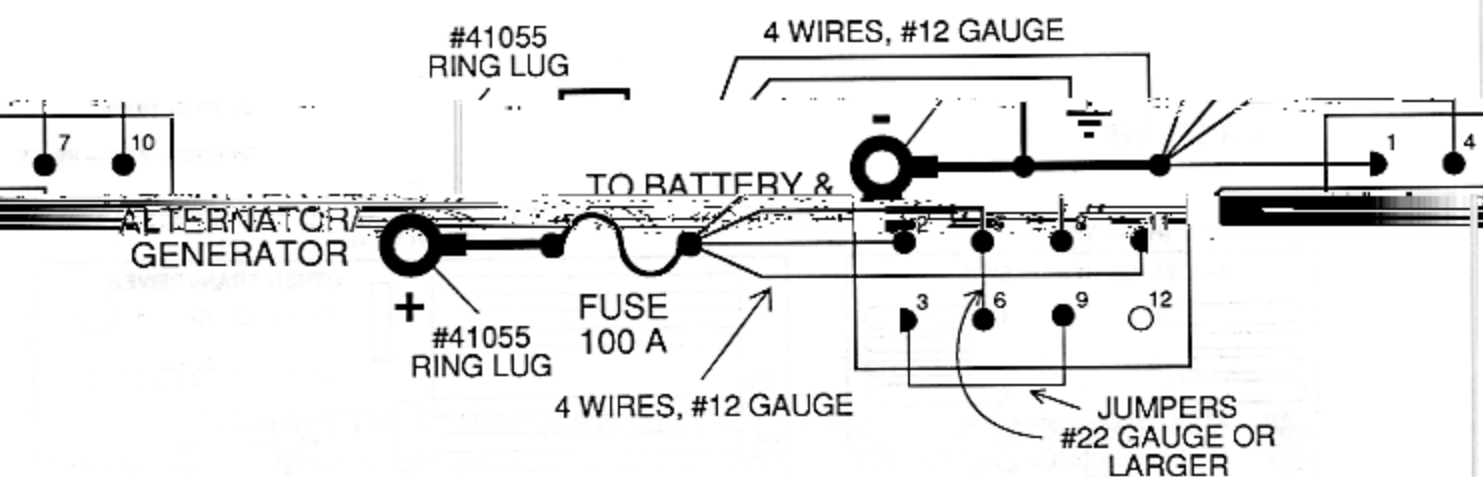

PIN NUMBER	FUNCTION	PIN NUMBER	FUNCTION
1	GROUND	7	GROUND
2	+14V @ 80A	8	+14V @ 80A
3	PWR SWITCH OUT	9	+14V SWITCHED
4	GROUND	10	GROUND
5	+14V @ 80A	11	+14V @ 80A
6	PWR SWITCH IN	12	NO CONNECTION

FIGURE 1-1. CONNECTION DIAGRAM FOR 12-14 VDC POWER

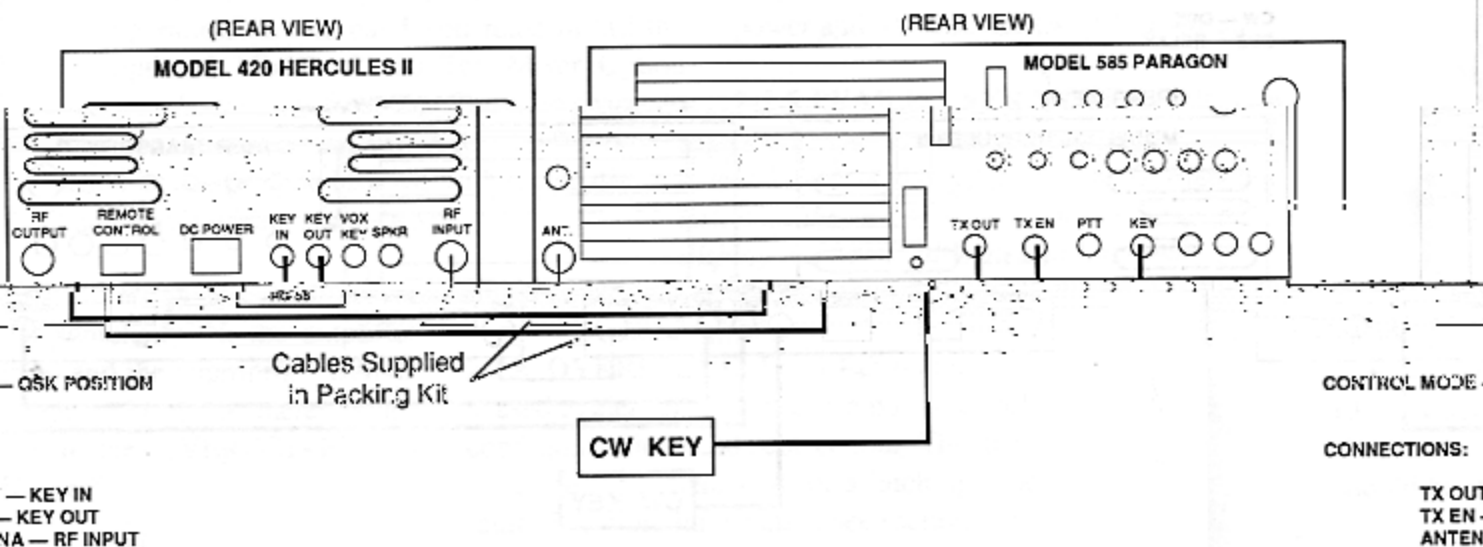

FIGURE 1-2. TEN-TEC TRANSCEIVERS (WITH TX OUT & TX EN)

CONTROL MODE

SSB (VOX/PTT) — RELAY

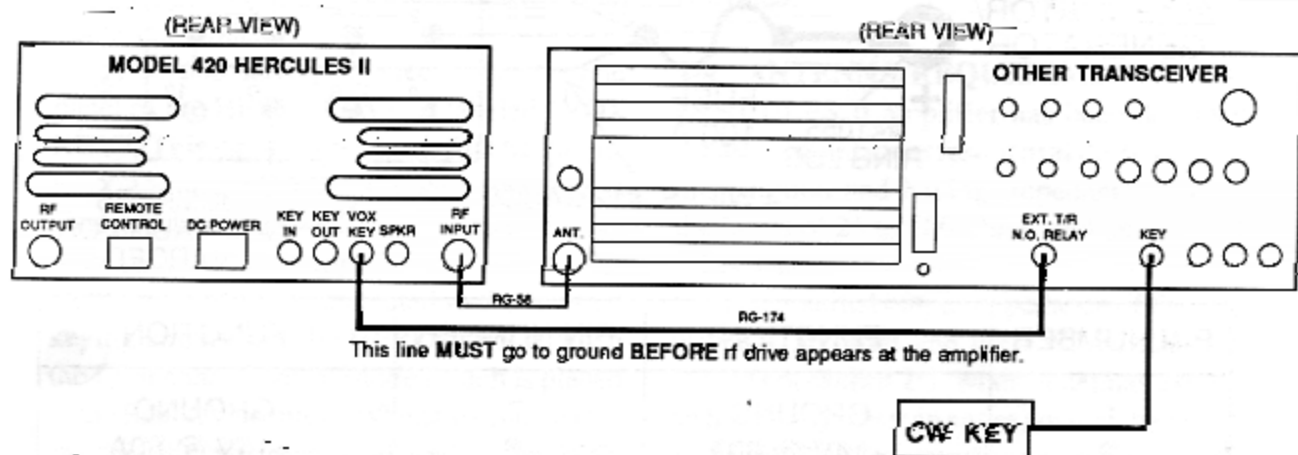

FIGURE 1-3. HOOKUP DIAGRAM FOR VOX RELAY CONTROL

CONTROL MODE

CW — QSK
SSB — RELAY

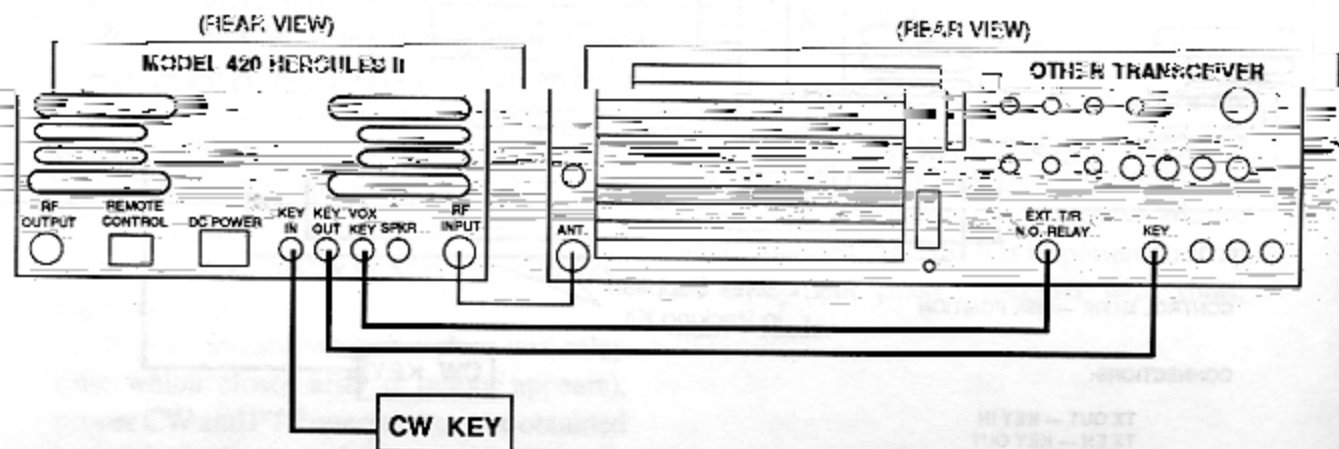

FIGURE 1-4. HOOKUP FOR OTHER TRANSCEIVERS WITH SLOW KEYING

OPERATING INSTRUCTIONS

2-1 INTRODUCTION The following instructions will enable the operator to quickly place the HERCULES II into operation. Included are descriptions of the Front Panel controls and Rear Panel connections followed by detailed Tune-Up procedures. Refer to CHAPTER 3 for further information and operating hints.

the KEY OUT signal is generated by the HERCULES II. This position is used for operation where fast keying is required. Placing the switch in the RELAY position allows the HERCULES II to be controlled by the relay. When in this position, the KEY IN signal is connected directly to the KEY OUT jack. This position is used for SSB (PTT/VOX) operation.

2-2.4 METER This switch is used to select what is being displayed on the built-in illuminated meter. When in the IC position it selects collector current, 150 Amps DC full scale. When in the VCC position it selects collector voltage, 200VDC full scale. When placed in the FWD position it selects forward power, 1000 watts full scale. The REF position selects reverse power and SWR scales (>3:1 full scale).

2-2 FRONT PANEL CONTROL FUNCTIONS The Front Panel controls and their functions are described below.

2-2.1 BAND This switch is used to select the desired frequency range of operation. This is an eight position switch and covers 1.8 through 30.0 MHz. The 22.0-30.0 MHz band position is normally inoperative. To enable operation on this band you must install the optional Model 420-10 Ten Meter Option board (available from Ten-Tec at no charge to

2-2.5 PEAK POWER METER This is a ten

2-3 REAR PANEL CONNECTOR FUNCTIONS

The following sections describe the rear panel connectors and their function.

2-3.1 RF INPUT This is a standard SO-239 receptacle designed for a mating PL-259 ("UHF" type) plug. RG-58/U or similar small 50 ohm coaxial cable is required to connect to the station exciter or transceiver's output or antenna jack. This cable should be as short as possible, preferably 3 feet or less.

2-3.2 RF OUTPUT This is a standard SO-239 receptacle designed for a mating PL-259 plug. RG-8/U or similar large coaxial cable rated for 1 KW must be used to connect to the antenna system.

2-3.3 DC POWER This connector provides the dc operating voltage to the amplifier and is designed for use with the Model 9420 Power Supply or for connecting another source of 12-14 VDC power to the HERCULES II. If a supply other than the Model 9420 is used, it must be capable of supplying 100 amps at 12-14 VDC. You should use four #12 gauge or larger wires for the positive and negative supply leads and keep the cable lengths as short as possible.

2-3.4 KEY IN This jack controls the HERCULES II's transmit/receive relay system. When used with the Model 585 PARAGON transceiver, this jack is connected to the TX OUT jack on the PARAGON. When used with other transceivers, a key or keyer is plugged into this jack.

2-3.5 KEY OUT When used with the Model 585 PARAGON, this jack is connected to the TX EN jack on the PARAGON. When used with other transceivers, this jack is connected to the transceiver KEY input jack.

2-3.6 VOX KEY IN This jack is used to control the HERCULES II's transmit/receive system when the Control Mode switch is placed in the RELAY position. This jack is normally connected to the external T/R (n.o. relay) connector on the exciter, and is used for keying the HERCULES II in SSB and VOX modes of operation.

2-3.7 SPEAKER This jack connects to the built in speaker in the HERCULES II cabinet. It may be connected to the external speaker connector on the exciter. The internal speaker is 8 ohms and is rated at 1 watt.

2-3.8 REMOTE CONTROL This connector is for controlling the HERCULES II from a remote location. When the BAND switch is in the REMOTE position, the HERCULES II BAND selection can be automatically set by a transceiver which provides the proper band information via this connector.

2-4 INITIAL TURN-ON

The following steps should be followed when turning on your HERCULES II:

- 1] Place the POWER switch in the OFF position.
- 2] Place the BAND switch on the desired operating frequency band or in the REMOTE position if a remote control cable is attached to a transceiver with band outputs (such as Ten-Tec PARAGON, OMNI or CORSAIR I).
- 3] Place the METER switch in the Vcc position to monitor the collector voltage at turn on.

2-5 TUNE UP PROCEDURE (CW/RTTY/SSTV/FM) The following procedure should be used for tuning up in all modes except SSB.

Turn the POWER switch ON. The meter lights and the proper band indicator should come on. The voltmeter should read about 14 volts and the fan should be running at low speed.

11. If either the OVERDRIVE indicator or the red segment of the bargraph display lights, reduce the exciter output slightly.

2-6 TUNE UP PROCEDURE

Select the desired band of operation or check that the band switch is in the 'B' position and the proper band is indicated if automatic bandswitching is being used.

Place the meter in the forward power (FWD) position.

Set the exciter rf power (ERF) control to minimum.

Place the excite in the tune (A.C.F.) key-down mode.

Increase drive from the exciter until the meter reads 500 watts forward power. The OVERDRIVE LED should remain off.

With the exciter, use a variable A.C. threshold separate from the rf power (A.C.F.) control, adjust the A.C. so that the forward power is limited to 500 watts.

Place the Control switch in either CSK or RELAY position depending on how you are keying the HERCULES II.

Using the METER switch, check that Icc is less than 80 amps, Vcc is 12.5-14 volts, and SWR is less than 2:1. The bargraph display should be indicating approximately 500 watts output.

Following procedure should be followed up in SSB mode.

1. Follow the tune up procedure in section 2-6 for steps 1-9.

2. Key the exciter in SSB mode and adjust the MIC gain for normal A.C. action. The bargraph display should indicate 500 watts output on voice peaks.

When the OVERDRIVE indicator or the red segment of the bargraph lights on voice peaks, reduce the exciter output slightly. The red bargraph segment lights at about 550 watts output.

Occasionally check the SWR while operating to make sure it remains below 2:1. Also, monitoring reflected power is useful in that any sudden change previous warning of antenna problems such as bad connections, antenna couple faults, transmission line flaws, or trap or balun failure. Particularly in the case of flashover (arcing) problems, the reflected power indication may flicker sharply upward only on high voice peaks.

2-7 FAULT CONDITIONS

Fault conditions can be divided into two groups: transient and latching. The transient conditions are overdrive and excessive power output. Overdrive is indicated by the "OVERDRIVE" LED.

to remove the fault condition, the indicator is extinguished and normal operation can continue. The latching fault conditions are over-

voltage, overcurrent, amplifier imbalance, and disabled band selected. These conditions result in constant illumination of the "OVER-DRIVE" indicator and the amplifier is automatically placed in the "BYPASS" mode, connecting the exciter directly through to the antenna. To clear a latching fault, turn the POWER switch off; correct the condition that caused the fault, and turn the POWER switch back on. Since most latching faults indicate a system defect of some kind, you may have to refer to the "ILLUSTRATIONS AND CIRCUIT SCHEMATICS" section of this manual and troubleshoot the cause. The disabled band selected fault is cleared by simply switching to a valid frequency band.

If you write Ten-Tec (and enclose a photocopy of your license), you will be sent a parts kit to enable operation on the 22-30 MHz band. There is no charge for this kit. See paragraph 3-1.3 for ordering information.

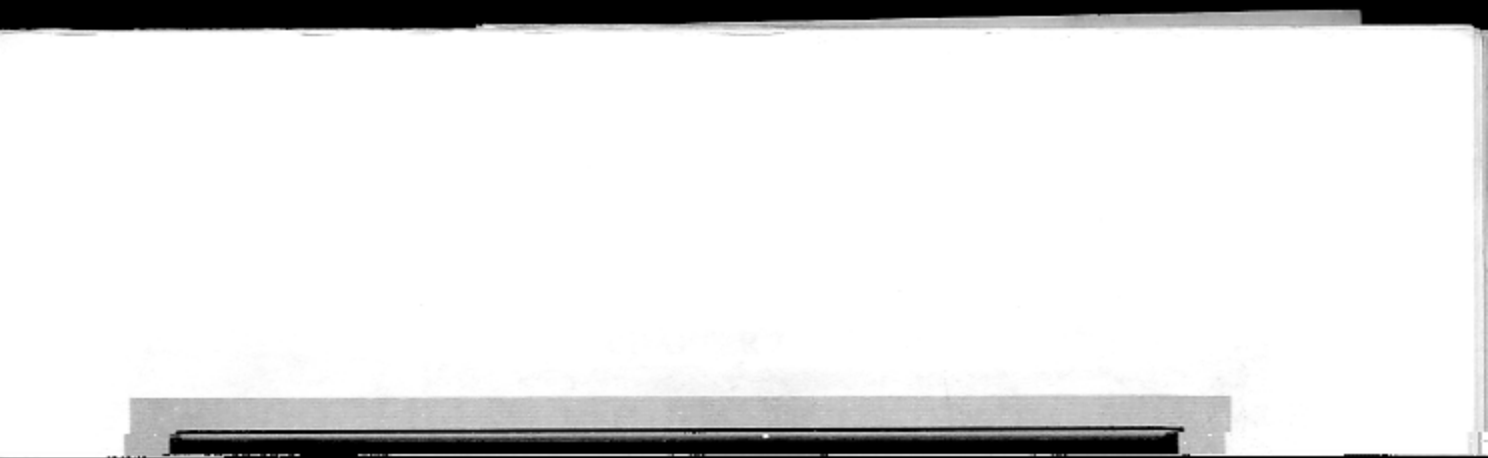

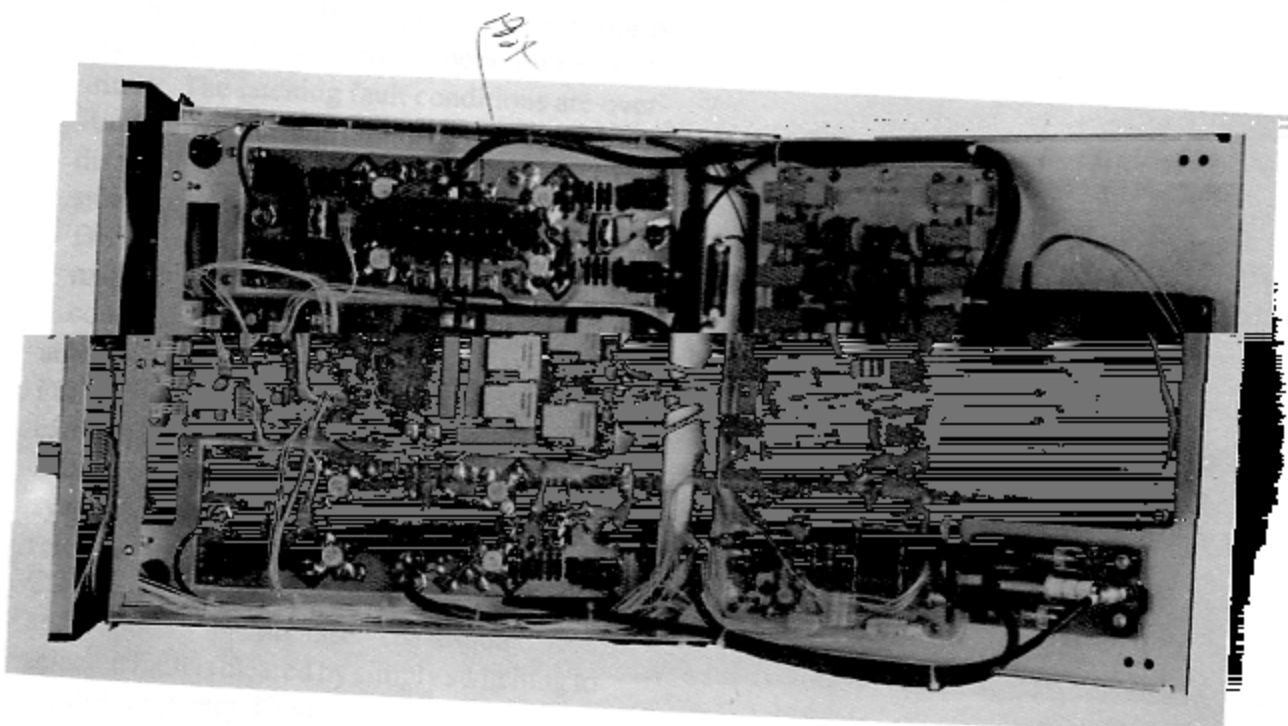

FIGURE 2-3. MODEL 420 TOP VIEW

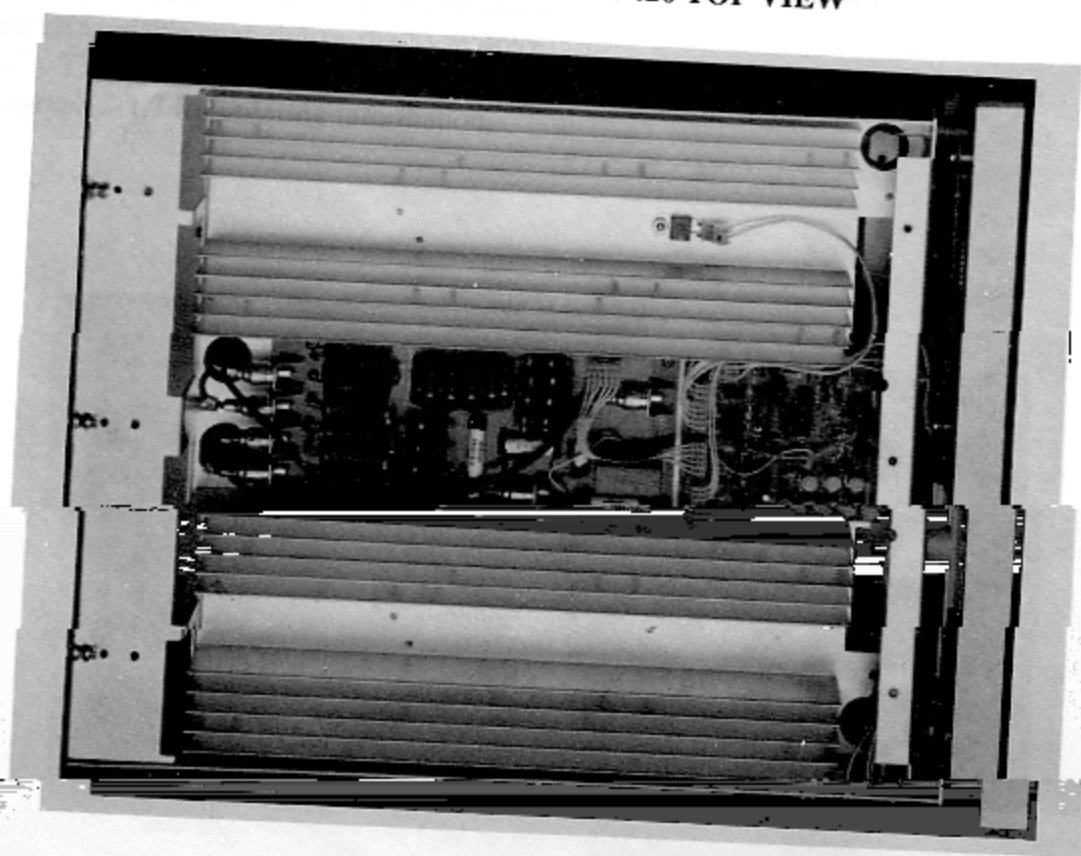

FIGURE 2-4. MODEL 420 BOTTOM VIEW

CHAPTER 3

OPERATING HINTS

3-1 INTRODUCTION The following paragraphs provide additional useful information

information out on unused pins on the DB-25 connector and cable them to the HERCULES

CHAPTER 3

OPERATING HINTS

3-1 INTRODUCTION The following paragraphs provide additional useful information for getting the best performance out of your HERCULES II.

3-1.1 REMOTE BANDSWITCHING

When the HERCULES II bandswitch is in the "REMOTE" position, the operating band is determined by band information input to the REMOTE CONTROL connector on the rear panel. Most transceivers that provide parallel band outputs (one wire for each band) can be adapted to control the HERCULES II. Some older Ten-Tec transceivers (OMNI & CORSAIR I) have a rear panel "LINEAR" connector. These can be connected to the HERCULES II with an adapter cable constructed according to FIGURE 3-1. Notice that since the HERCULES II is a general coverage HF amplifier, some amateur bands share a band position on the amplifier and one amplifier band is unused. If the cable is wired correctly, the HERCULES II will automatically select the proper general coverage band for the amateur band in use.

Ten-Tec PARAGON transceivers can be adapted to the HERCULES II remote control connector through the rear panel DB-25 connector that is used for the RS-232 computer interface. If you have the computer interface (accessory Model 258), order the Ten-Tec Model 236 Remote Bandswitching Kit and follow the instructions enclosed. This kit contains the additional internal and external cables needed to bring the PARAGON band

information out on unused pins on the DB-25 connector and cable them to the HERCULES II REMOTE CONTROL connector. If you do not have the computer interface installed, order the Ten-Tec Model 237 Remote Bandswitch Connector Kit and follow the instructions enclosed with the kit. This kit contains a DB-25 Connector Board and the necessary internal and external cables to provide the remote bandswitching function only.

3-1.2 TOTAL REMOTE CONTROL In addition to the bandswitching lines, the rear panel REMOTE CONTROL connector provides all of the control and metering connections necessary for complete remote control of the HERCULES II. A Model 9423 Remote Control Head and cable assembly will be available from Ten-Tec. Refer to the manual enclosed with the control head for installation and operating instructions.

3-1.3 OPERATION ON THE 22-30 MHZ BAND To enable the HERCULES II for operation on the 22.0-30.0 MHz band, the Model 420-10 Ten Meter Option must be installed. To obtain the Model 420-10 Ten Meter Option kit, at no charge to you, just mail in a photocopy of your license, your warranty card with the serial number of your HERCULES II, and a note requesting the Model 420-10 Ten Meter Option Kit to:

9/15/74 g p c e n

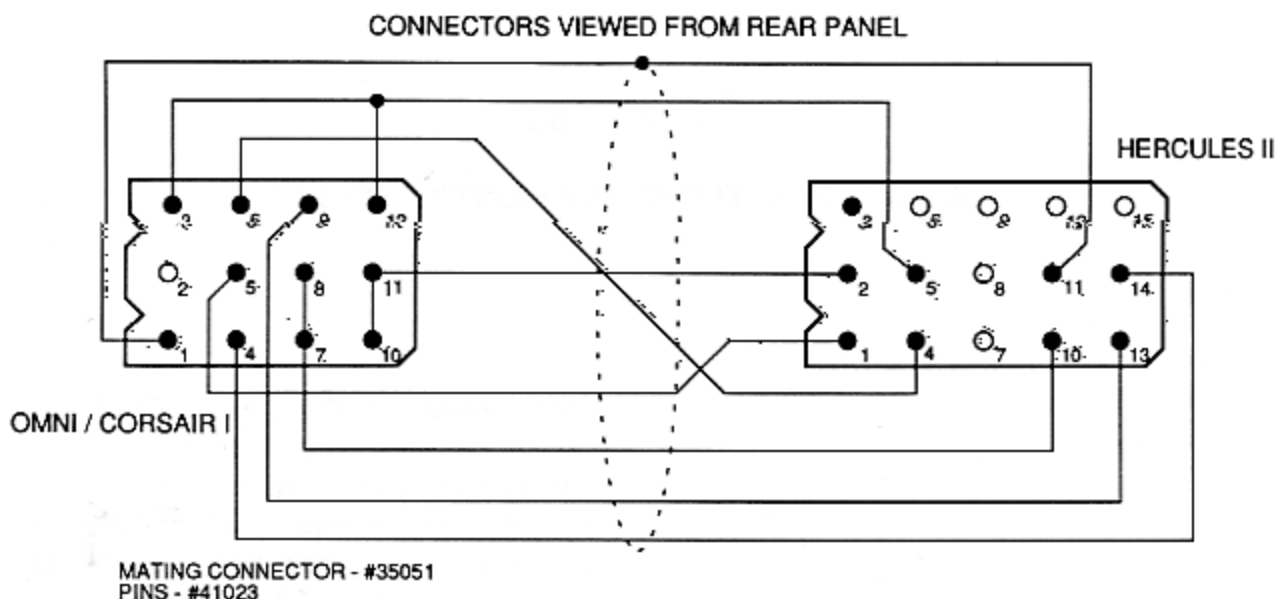

FIGURE 3-1. REMOTE BANDSWITCH ADAPTER CABLE — OMNI / CORSAIR I

<u>OMNI / CORSAIR I PIN NUMBER</u>	<u>FUNCTION</u>	<u>HERCULES II PIN NUMBER</u>
1	GND & SHIELD	11
2	T	—
3	10M, 22-30 MHZ	5
4	COMM, PWR ON	14
5	160M, 1.7-2.5 MHZ	1
6	80M, 2.5-4 MHZ	4
7	40M, 6.5-10.5 MHZ	10
8	30M, 6.5-10.5 MHZ	10
9	20M, 10.5-15 MHZ	13
10	18M (17M), 15-22 MHZ	2
11	15M, 15-22 MHZ	2
12	10M, 22-30 MHZ	5
	4-6.5 MHZ	7
	FWD	3
	KEY	6
	FAULT	9
	REV. ?	15
	KEY OUT	12

close SW + 14

FIGURE 3-2. HERCULES II REMOTE CONTROL CONNECTOR P

CHAPTER 4

ILLUSTRATIONS AND CIRCUIT SCHEMATICS

4-1 INTRODUCTION The following sections contain circuit trace drawings and detailed component layout diagrams for all of the printed circuit board subassemblies used in the Model 420 Solid State Linear Amplifier. These drawings are followed by fold-out schematic diagrams for each circuit board subassembly. In addition, there is an overall wiring diagram for the Model 420 Linear Amplifier.

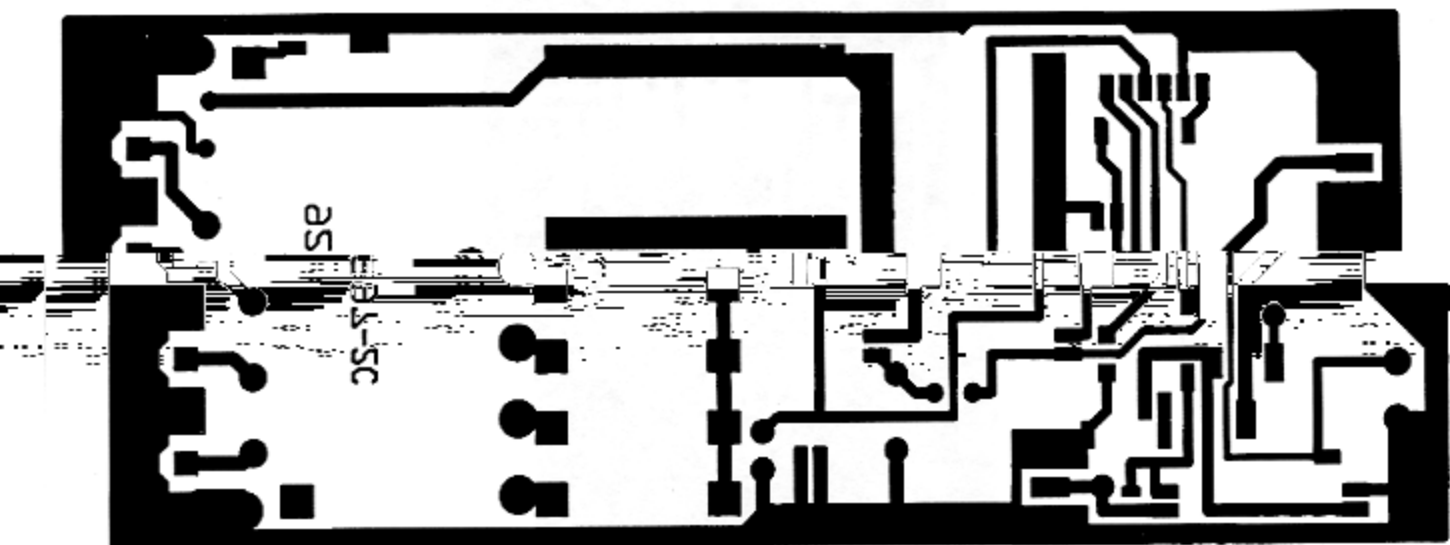
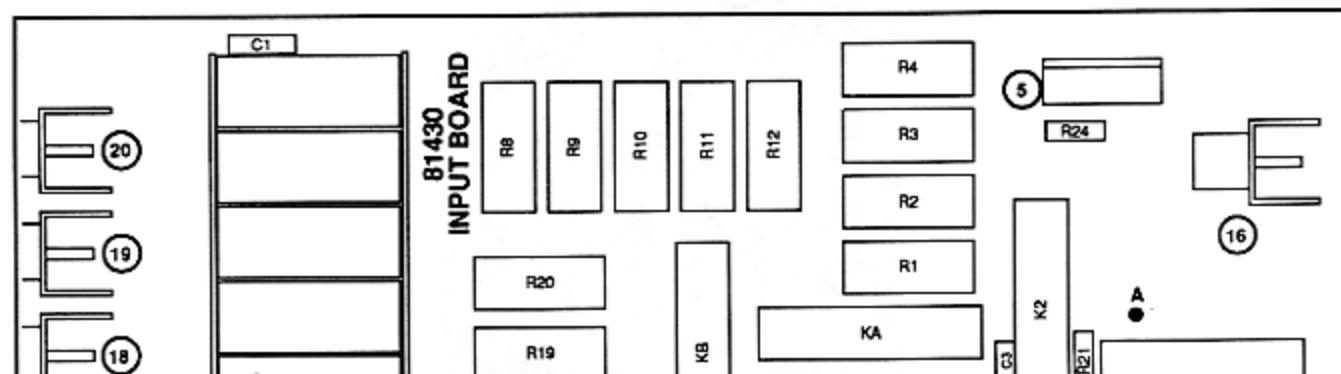

FIGURE 4-2. 81430 INPUT SPLITTER BOARD CIRCUIT TRACE



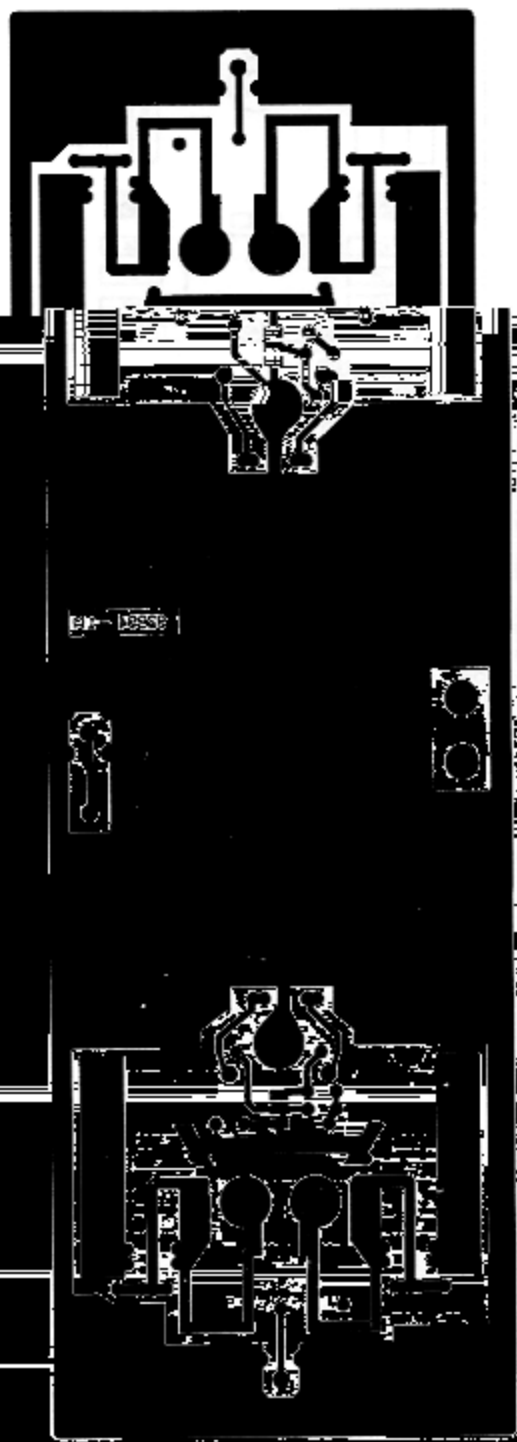

FIGURE 45. 5127 MP POWER AMP BOARD LAYOUT FRAMES, BOTTOM

